

12GSRWP GLOBAL STANDARD ROTARY WELLPOINT

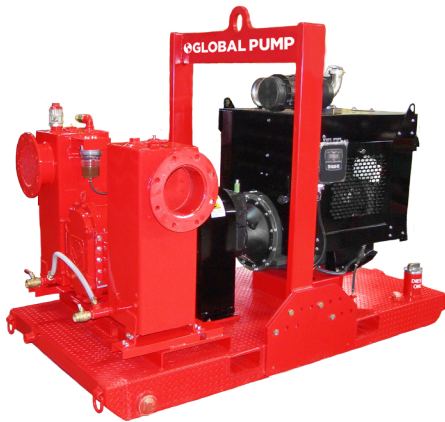

Global Pump® Standard Rotary Wellpoint pumps are specifically designed for wellpoint and underdrain dewatering applications.

Capable of handling both water and air, Global Standard Rotary Wellpoint pumps automatically prime and reprime without air elimination systems or operator intervention. Ease of application is inherent, as the positive displacement pump automatically develops the discharge pressure required.

The model 12GSRWP is capable of achieving maximum flows of 3,200 gpm (726 m³/h) and maximum discharge pressures up to 25 psig, while handling water, air and solids up to 2.5" (63.5 mm) in diameter.

The standard 12GSRWP is powered by a water-cooled, 4-cylinder diesel engine with reduction gearbox. Alternative drives are available, including other diesel engines or electric motor options.

FEATURES

Global Pump's proven Rotary Helical Lobe pump with pulsation-free convoluted, 4-lobe rotors

Replaceable wearplates for both front and rear covers for extended cover life

Silicon Carbide mechanical seals

Direct drive through a flexible coupling and engine-mounted reduction gearbox

Gearbox technology separates the pump head from the gearbox, eliminating cross contamination between pump media and gearbox lubricant

Large suction and discharge header tanks for easy priming, draining and solids settlings

Recirculation line between header tanks to ensure rotors are always wetted

Standard engine control panel provides preset emergency shutdown protection and allows the addition of automatic level control

Rotors, cover seal and product seals can be accessed for inspection, service or replacement by simply removing the front cover

Disassembly of the inlet and outlet pipework and pump housing is not necessary

Standard skid-mounted format with integral fuel tank, tie downs, lifting bail

OPTIONS

Fuel tanks for extended run times and/or remote location as required

Highway trailer with integral fuel cell/chassis, lights, fenders, tie downs, lifting bail, front and rear jacks. Trailer brakes can be offered as required

Sound attenuated enclosure options

Hose racks, accessory containers and other custom features available as required

Wide range of suction and discharge fittings including Global Pump's own "QD" QuickDisconnect fittings and accessories

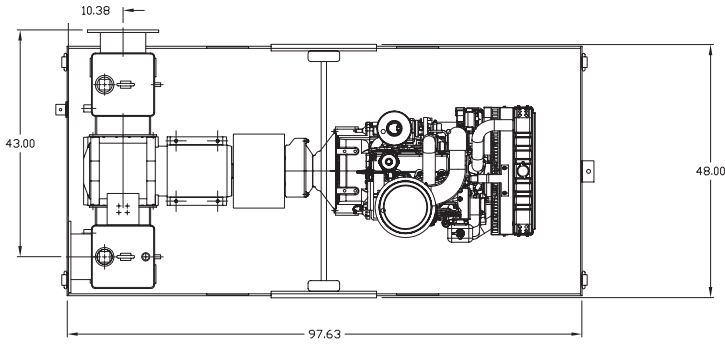
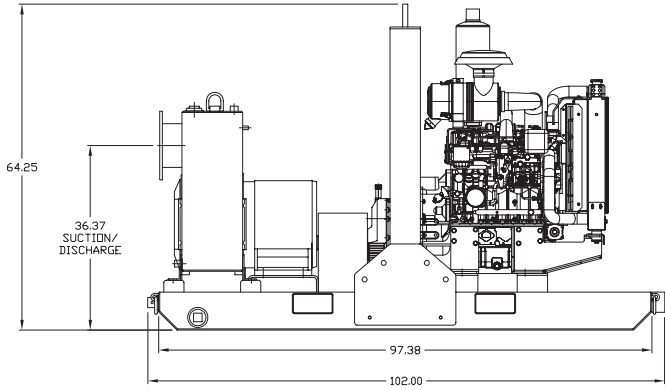

SPECIFICATIONS

Connections	12" (300 mm) ANSI Flanges
Maximum Pump Speed	600 rpm (300-500 rpm normal operating range)
Maximum Engine Speed	2,196 rpm (1,098-1,830 rpm normal operating range)
Maximum Flow	3,200 gpm (726 m ³ /h) (428 cfm) of water or air at 600 rpm pump/2,196 rpm engine
Water Temperature Limit	140° F (60° C)
Solids Handling Capability	2.5" (63.5 mm)
Maximum Casing Pressure	75 psig (517 kPa)
Standard Compact Fuel Tank	120 gallons (454 liters)
Dry Weight	4,300 lbs.

PUMP MATERIAL

Casing	Aluminum
Rotors	NBR with cast iron core
Bearing Housings	Aluminum
Bearing Covers	Aluminum
Wearplates	Stainless Steel
Timing Gears	Case Hardened Steel
Shafts/ Shaft Sleeves	Steel/Stainless Steel
Seal	Silicon Carbide on Silicon Carbide
Fuel Cell/Chassis	Steel

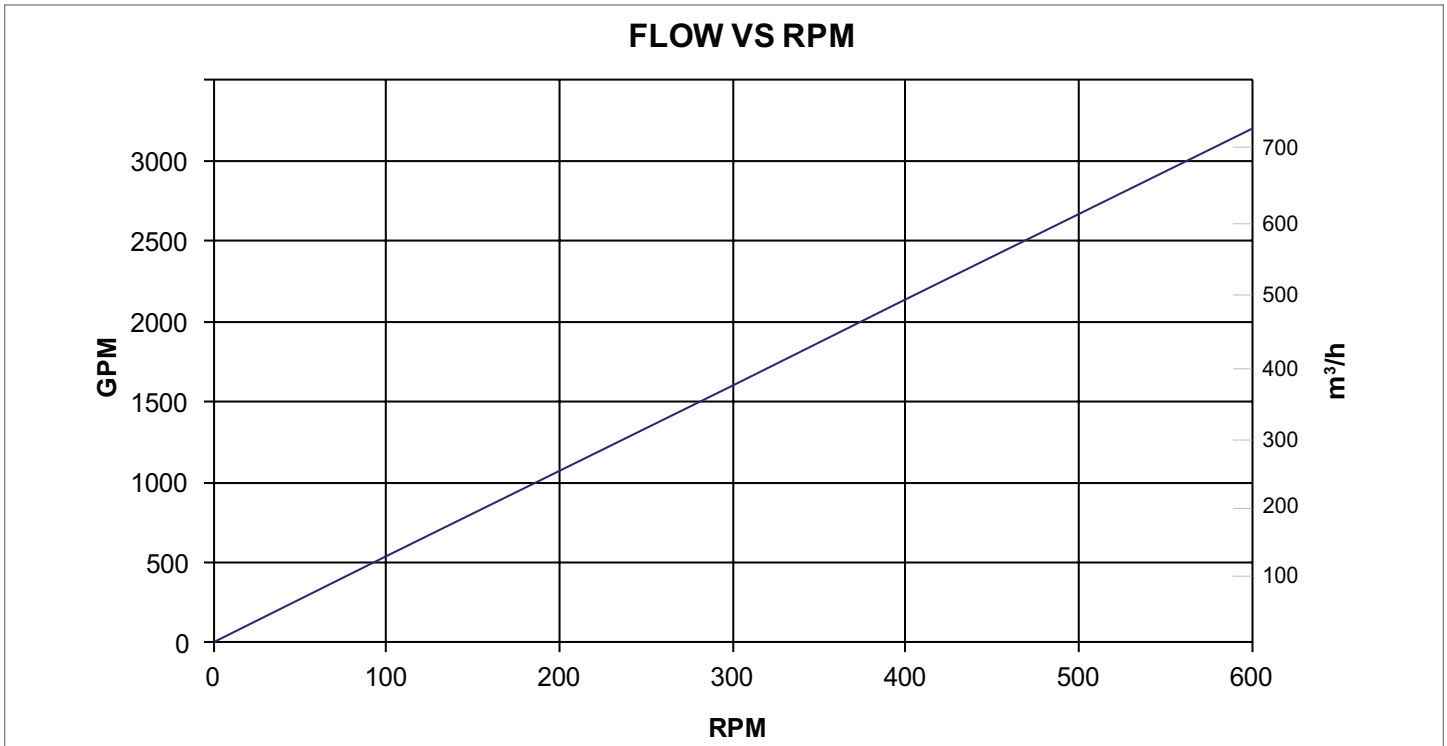

GLOBAL PUMP
 10162 East Coldwater Road, Davison, MI 48423
 Tel: 810.653.4828 Fax: 810.658.0632
1.866.360.PUMP www.globalpump.com