



12" WELLPOINT PUMP



Designed for applications where high reliability and ease of use are of paramount importance, the Global Pump 12" Wellpoint pump (12WP) is capable of handling long wellpoint and underdrain dewatering systems, and large volumes of air and water. The 12WP is also well suited for conditions that result in intermittent flow because it is equipped with a fully automatic vacuum-prime dry priming system. The dry prime system will automatically prime and reprime the pump while it is running to eliminate down time. The 12WP is capable of achieving maximum flows of 4890 US gallons per minute (1110.52 m³ per hour) and 186 feet (56.69 m) total head, while handling solids up to 1.00" (25.4 mm) in diameter. The 12WP also has a high efficiency air separation tank that is mounted on the suction end of the pump so that the air and water are separated before entering the pump case.

Features

- ❑ A belt driven Masport (model M-15) vacuum pump powers the automatic priming system with an airflow capacity of 307 C.F.M.
- ❑ The enclosed engine control panel features preset emergency shutdown protection against low oil pressure and high coolant temperature
- ❑ The pump's mechanical, self-aligning rotary seal has mating faces of carbon vs. ni-cad. The elastomers are of synthetic rubber, the cage and spring are of stainless steel no. 316
- ❑ The non-return check valve that forms a 90-degree flanged discharge fitting, and allows 100% flow area without restriction, resulting in minimal head loss and clog free operation.
- ❑ Compact design with an integral 205 US gallon (775.93 liters) fuel tank, allowing for 24Hr. plus operation. The chassis is offered in either skid or highway legal trailer format
- ❑ The condensation chamber controls and contains any condensation or water vapor from the air separation chamber and is fitted with a drain valve
- ❑ Global's ultra efficient oil recovery system separates and removes oil particulates and other airborne pollutants from air discharged from the vacuum pump
- ❑ Sound absorbent acoustic enclosure option is available for use in noise sensitive areas
- ❑ The air separation tank features a large inspection cover

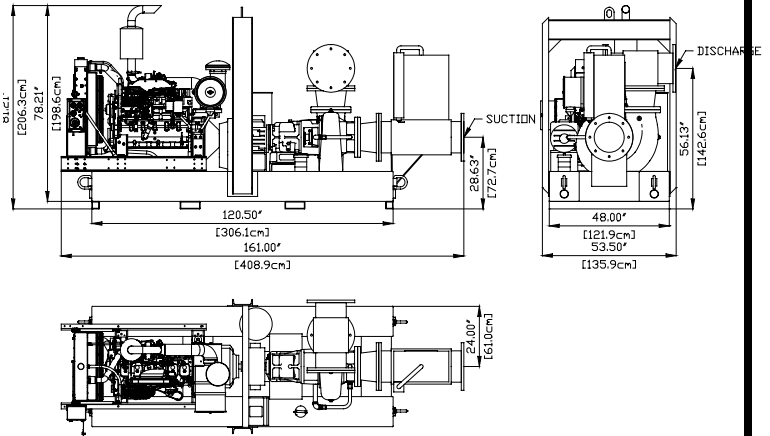
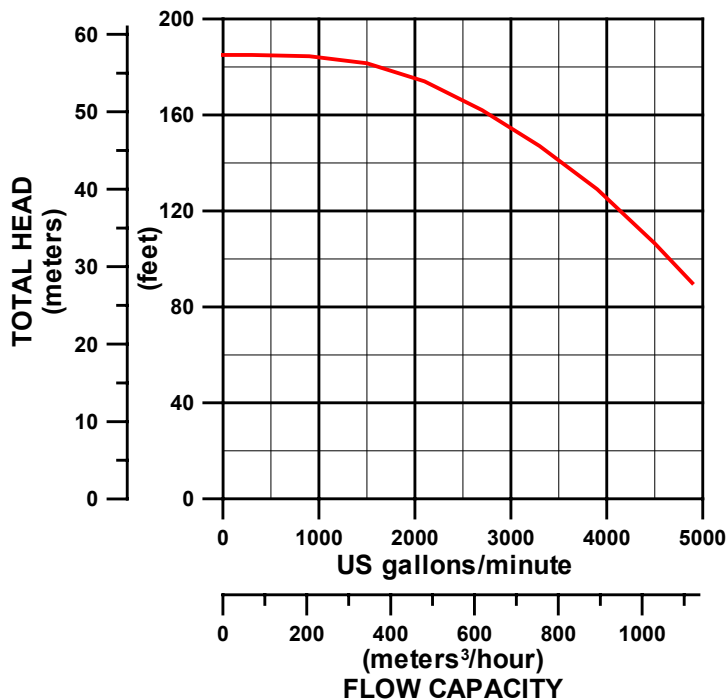

Specifications

- ❑ **Maximum Operating Speed:** 1750 rpm
- ❑ **Maximum Operating Temperature:** 212°F (100°C)
- ❑ **Solids Handling Capability:** 1.00" (25.4 mm) diameter using standard impeller
- ❑ **Fuel Consumption:** Approximately 6.3 US gallons per hour (23.85 liters per hour) @ 1750 rpm
- ❑ **Integral Fuel Tank Capacity:** 205 US gallons (775.93 liters), providing approximately 32.54 hours of running time
- ❑ **Oil Recovery Tank Capacity:** 4 US Gallons (15.14 liters)
- ❑ **Vacuum Pump Air Flow:** 300 cfm (8495.1 liters/ min)
- ❑ **Flange Connections:** 12" (304.8 mm) x 12" (304.8 mm) diameter

Materials

- ❑ **Pump Casing, Suction Cover:** Class 30 Cast Iron
- ❑ **Impeller:** Class 25A Cast Iron
- ❑ **Impeller Shaft:** Steel AISI 1045
- ❑ **Mechanical Seal:** Carbon / ni-cad
- ❑ **Chassis:** ASTM A36 Steel
- ❑ **Air Separation Tank:** ASTM A36 Steel
- ❑ **Air Separation Valve Body and Seat:** AISI 316 Stainless Steel with Neoprene Elastomers
- ❑ **Vacuum Pump Casing:** Class 30 Cast Iron
- ❑ **Non-Return Check Valve:** Steel With Weighted Reinforced Neoprene Seat

Pumps: Sales, Parts & Service



Global Pump Company

10162 East Coldwater Road, Davison, MI 48423

Tel: (810) 653-4828 Fax: (810) 653-7828

www.globalpump.com